

## LOCINOX-ELECTRADROP-R-9005



### MOTORIZED ELECTRICAL DROP BOLT

Electric 24V drop bolt with 120 mm throw for safe locking of automated swing gates. The long-lasting internal batteries automatically lift the drop bolt in case of a power outage, eliminating the need for a key. Thus assuring a free exit of the premises. By securing your gate with an Electradrop you add an additional secure latching and disburden the electric gate motors.

#### FEATURES

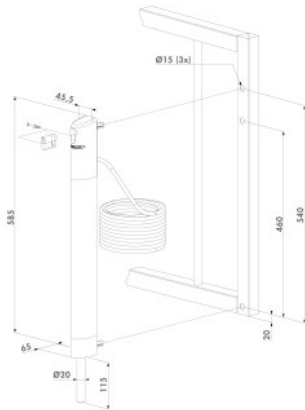

- Vandal-proof, powder coated aluminium housing
- To be connected to the warning light on automated gates (min 3 sec prewarning signal) or directly on the gate automation
- Automatic detection and memorisation of the continuous or pulse signal
- Mechanical release possible (by key) in case of emergency
- The integrated obstacle detection will automatically stop the drop bolt movement in case of overpressure to avoid injuries.
- Throw: 120 mm (with the exception of Electradrop-ZILV: 115 mm)
- Drop bolt diameter: 20 mm
- For gate profiles: 40 mm or more
- 5 m cable included
- Power consumption: Normal: 25 W / Peak: 55W / Standby: 0,2 W
- Included: 3012-37-STD cylinder
- To connect to a Locinox PowerStone 60W